

MecALAC

AS900^{tele}



AS900^{tele}

MecALAC



**EXPERIENCE
OF YOUR WORKSITE**
AS900TELE

AS900 tele



For decades, Mecalac has been developing and producing high-quality and innovative wheel loaders at the Büdelsdorf site in Northern Germany.

With our articulated loaders, four-wheel steered front, telescopic and swing loaders, we are the only manufacturer to offer all concepts for compact loaders. At Mecalac you can choose the best suitable solution for your application.

The unique Mecalac AS900tele convinces with its enormous reach and lift height as well as with its broad range of applications. With an extensive number of attachments, it is an indispensable all-season working equipment, in particular in municipal areas.

HANDLE YOUR DAILY WORKSITE PROCESS FAST AND EFFICIENTLY - THAT'S WHAT MECALAC SWING LOADERS STAND FOR

Mecalac swing loaders are compact, versatile, comfortable, safe and extremely powerful. They are characterised by the highest stability paired with maximum agility and efficiency for every worksite. They allow work tasks to be completed faster and therefore more productively. The key to productivity is that you can simultaneously drive, steer and swing while performing your daily loading work.

SUMMARY

+



6 LET'S HAVE A LOOK AT YOUR ADVANTAGES



8 MECALAC TELESCOPIC ARM



LET'S HAVE A LOOK AT YOUR **+** ADVANTAGES

FIRM GRIP ON YOUR WORK PROCESS WITH THE AS900TELE

Mecalac swing loaders are compact, versatile, comfortable, safe, and extremely powerful. Their increased profitability and their innovative swing system have been the key for long-term market leadership in the swing loader sector which they continue to expand.

The AS900tele combines the advantages of a telescoping wheel loader and a swing loader in a single machine. The enormous lift height and reach make machine operation even more profitable. In this way, you can complete your daily work tasks fast, safely, accurately and without any compromise.

- PANORAMA CAB WITH 2 DOORS ON BOTH SIDES FOR EASY ACCESS
- RIGID CHASSIS
- FOUR-WHEEL STEERING FOR MAX. STABILITY AND FOR EXCELLENT MANOEUVRABILITY
- LOAD-DEPENDENT AXLE SUPPORT
- CHAIN OPERATED SWING SYSTEM WITH CONSTANT AND PRECISE SWING SPEED
- TELESCOPIC ARM WITH Z-KINEMATICS FOR PRECISE PARALLEL LIFTING
- ELECTRO-HYDRAULIC QUICK-COUPLER
- OPTIMAL ACCESS TO ALL SERVICE POINTS
- WIDE RANGE OF ATTACHMENTS







STRONG!
MECALAC TELESCOPIC ARM



TELES- COPING

POWERFUL

LIFT HEIGHT AND REACH

The telescopic arm designed by Mecalac was engineered to be rigid and to offer optimum visibility. The swing function increases the effective working area to 180°. The bucket volume range is 0.7-1.2 m³ (0.92-1.6 yd³).

Featuring a maximum lift height of 4.72 m (15'5") with pallet forks, a maximum reach of 3.50 m (11'5") and a maximum fork payload of 2135 kg (4,707 lb), the AS900tele lets you safely and easily complete even demanding tasks.

The zero-play chain swing system providing constant working speed allows easy, efficient and precise work cycles for high productivity.





STABLE
PERFECT DURING OPERATION

COMPACT AND AGILE

The AS900tele is the only telescopic swing loader with four-wheel steering.

The extremely robust rigid chassis with four-wheel steering is the basis for maximum stability at maximum performance because the footprint remains unchanged at all times. A turning radius of only 3.71 m (12'2") across the rear warrants the highest possible mobility, even on most confined work sites.

The telescoping arm featuring a swing range of 180° adds to the famed agility and flexibility of the loader that lets you quickly and efficiently complete every task. It is the interplay of our Mecalac technologies that distinguishes our loader and has made it so successful until today.

Flexibility. Performance. Safety.

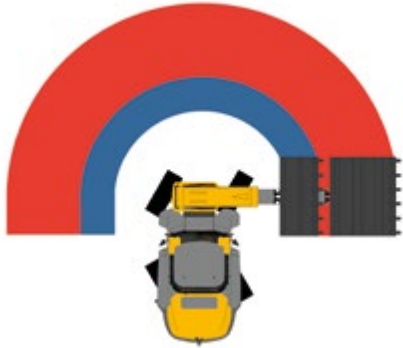



SPACIOUS OVERVIEW & COMFORT

MECALAC PANORAMA CAB

The spacious cabin and the ergonomically laid out controls offer a convenient workplace for long-term work. Large tinted glass panes ensure an excellent all-round vision which is complemented by two large, hinged rear view mirrors. The mirrors can even be heated as an option. The panorama roof provides an exact overhead view, for example for truck loading. In this way, the telescopic arm and the work area are always in your field of view.





COMFORTABLE AND ERGONOMIC



YOUR WORKPLACE

A multi-position comfort seat, convenient oddment trays, ample storage space and a powerful 3-stage ventilation and heating system make daily work a pleasure. A washer system keeps the large front and rear windows clean even in bad weather. A perfect vision is essential, especially in winter. For this reason, the AS900tele comes with a heated rear window. The even, single-piece floor mat allows for simple and fast cleaning. Due to a great number of equipment options, individual demands on the interior features can be accounted for.





VERSATILE
POWER IN EVERY SECTOR



THE AS900TELE PERFORMING ALL-SEASON MUNICIPAL WORK

The multi-faceted tasks of communes, road maintenance depots, horticulture and landscaping as well as construction enterprises require an equally versatile machine.

Whether sweeping in summer or snow clearing and salting in winter: The AS900tele is always a warrantor for clean areas. Operation with a professional mulcher is also an efficient variant for the municipal area. In this way, shoulders or shrubs on the kerb can be quickly and easily taken care of.



THE RIGHT TOOL FOR EVERY TASK



↓ TECHNICAL DATA

- Rigid, single-frame chassis for max. stability
- Four-wheel steering system with automatic alignment allows minimum turning radius
- Zero-play, chain operated 180° swing system
- Telescopic boom with Z-Kinematics
- Hydraulically controlled quick-coupler with electric safety device
- High-performance, power-controlled, hydrostatic four-wheel drive
- Planetary axles with self-locking differential on front axle
- Low-maintenance wet lamella brake
- Comfortable panoramic driver's cabin with ROPS/FOPS safety system
- Servo-assisted joystick controls
- Wide range of attachments

DATA

Operating weight	7250 kg (15983 lb)
Engine power	55.4 kW / 75 hp (74.3 imperial hp)
Bucket capacity	0.70 – 1.20 m ³ (0.92 - 1.6 yd ³)

ENGINE

Low-noise, water-cooled Deutz TCD 2.9 L4 turbo diesel engine with intercooler. Common Rail injection system, cooled external exhaust gas recirculation, diesel oxidation catalyst (DOC).	Tier IV Final* Stage 5* - Diesel Particulate Filter (DPF)	
Net power at acc. to ISO 14396	2300 rpm 55.4 kW / 75 hp (74.3 imperial hp)	2300 rpm 55.4 kW / 75 hp (74.3 imperial hp)
Max. torque at acc. to ISO 14396	1600 rpm 300 Nm	1600 rpm 300 Nm
Air intake filter: 2-level dry-air filter with safety cartridge	•	•
Electrical system: Operating voltage Battery capacity Alternator rating	12 Volt 95 Ah 120 A	12 Volt 95 Ah 120 A

DRIVE

Hydrostatic drive with automotive control, 2 stages for maximum propulsive force, shiftable under load, multifunctional lever (joystick) for drive and working hydraulics control	•
Axles: planetary axles with four-wheel steering for maximum manoeuvrability, oscillating rear axle with suspension	•
Differential lock: self-locking differential in front axle	•
Wheels: - Tyre size - Optional	16/70-20 405/70 R20
Speeds: - Road gear - Field gear	0-20 km/h (0-12 mph) 0-5 km/h (0-3.10 mph)
Oscillation: max. oscillation angle	+/-10°

*According to National regulation

BRAKES

Working brakes:	
1. Hydrostatic inching brake	•
2. hydraulically operated, servo-assisted wet lamella brakes on front axle, acting on all 4 wheels	•
Parking brake: hydraulically operated spring loaded brake, acting on all 4 wheels	•

STEERING

Hydrostatic four-wheel steering with 3 steering modes with automatic alignment (four-wheel, front-wheel and crab steer)	•
Max. steering angle	+/-35°
Turning radius, measured over: rear	3710 mm (12'2")

HYDRAULIC SYSTEM

Dual-circuit system with gear pumps	
1. Working hydraulics circuit (lift/lower, tilt, telescopic functions, accessories), and steering (via priority valve); three-way control valve with primary and secondary safeguards	•
Max. operating pressure at 2300 rpm	84 l/min (22.2 gal/min) and 240 bar (3480 psi)
2. Circuit (swivelling) single control valve with primary and secondary safeguards	•
Max. operating pressure at 2300 rpm	35 l/min (9.2 gal/min) and 220 bar (3190 psi)
Float position for lifting cylinders	
Cylinders: 1 lifting cylinder	•
1 tilting cylinder	•
2 swing cylinder	•
1 telescopic cylinder	•

PERFORMANCE DATA

Bucket position:	
- Crowd angle	45°
- Dump angle top	45°
Lifting force	3700 daN (8,318 lbf)
Breakout force	4800 daN (10,790 lbf)
Thrust force	4500 daN (10,116 lbf)
Tipping load, telescope retracted:	
- Standard bucket, max. steered, straight	2950 kg (6,504 lb)
- Standard bucket, max. steered, 90°-swivelled	2320 kg (5,115 lb)
Payload on forks, telescope retracted: max. steered, frontal, even terrain	2135 kg (4,707 lb)
Tipping load according to ISO 14397; Payload according to EN 474-3	

FILLING CAPACITIES

Engine with filter	approx. 8 l (2.1 gal)
Fuel tank	approx. 130 l (34.3 gal)
Front axle total	approx. 11 l (2.9 gal)
Rear axle with gearbox	approx. 12 l (3.2 gal)
Hydraulic system with tank	approx. 134 l (35.4 gal)

NOTE: METRIC MEASUREMENTS ARE THE CRITICAL VALUES

- 1 Litre = 0.26417 US Liquid Gallons
- 1 Litre = 0.21997 Imperial Liquid Gallons

CHASSIS

Rigid, single-frame chassis with rear axle support for maximum stability, especially when working in swivelled position	•
Sealed articulated/oscillated pivot with play-free, chain operated swinging system with constant turning speed and power	•
Telescopic boom with Z-Kinematics for exact parallel lifting	•
Operator's cab with flexible four-point mountings for maximum driver comfort and minimum noise levels	•
The servo-assisted joystick controls are smooth, accurate and long lasting	•

STANDARD FEATURES

Amplly dimensioned ROPS panoramic comfort cabin with 2 lockable doors	•
FOPS grid for cabin roof	•
Doors can be locked in 2 positions within the contour of the loader	•
Single piece floor mat for easy cleaning	•
Tinted windows	•
Parallel guided windscreen wiper	•
Rear wiper	•
Front and rear screen washing device	•
Heated rear window	•
2 large fold away outside mirrors	•
Tinted roof window	•
Steering column is adjustable in height and inclination	•
Ergonomically adjustable joystick	•
Multiply adjustable driver's seat	•
Safety belt	•
Sun visor	•
Heating and ventilation system with recirculation air function	•
Main battery switch	•
Interior light	•
12 V socket	•
Coat hook	•
Storage pockets in the cabin	•
Storage box with lid	•
Lockable storage compartment at the chassis	•
Intuitive modular control panel with onboard computer for machine monitoring	•
2 driving lights on cabin roof	•
2 working lights at monoboom	•
Single key system	•
Hydraulic quick coupler with electric safety device	•
Towing coupling	•
Fastening and lifting points	•
Proportional 1 st auxiliary hydraulics circuit is integrated in the joystick	•
Color scheme: yellow	•
Operator's cabin, axles and wheels: grey	•

OPTIONAL EQUIPMENT

35 km/h (22mph) version	•
Wide tires	•
Beacon light	•
Interior mirror	•
Acoustic back up alarm	•
2 nd auxiliary hydraulics	•
Permanent function for auxiliary hydraulics	•
High performance hydraulic	•
Safety valves	•
Boom suspension	•
Bio-degradable oil fill for hydraulic system	•
Pressureless return line	•
Inching speed	•
Lockable differential on rear axle	•
Sliding windows right and left	•
Air-conditioning system	•
Air suspended driver's seat	•
Radio	•
Heated outside mirrors	•
Immobilizer	•
2 working lights rear	•
LED working lights front and rear	•
Trailer coupling	•
Special corrosion protection for salt applications	•
Attachments as per separate list as pallet fork, load hook, salt- and sandspreader, etc	•

EMISSIONS

Engine: Emissions according to EU-RL 97/68	Tier IV Final*	
	Stage 5* - Diesel Particulate Filter (DPF)	
Noise emission:		
Sound power level LWA ¹	100 dB(A)	100 dB(A)
Acoustic power level LpA ²	75 dB(A)	75 dB(A)
Vibrations:		
Vibration total value ³	< 2.5 m (8'2")/s ²	< 2.5 m (8'2")/s ²
Effective vibration level ⁴	< 0.5 m (1'7")/s ²	< 0.5 m (1'7")/s ²

*According to National regulation

¹ According to 2000/14/EG

² According to ISO 6396

³ According to ISO/TR 25398

⁴ According to ISO/TR 25398

Standard and optional equipment may vary. Consult your Mecalac dealer for details.

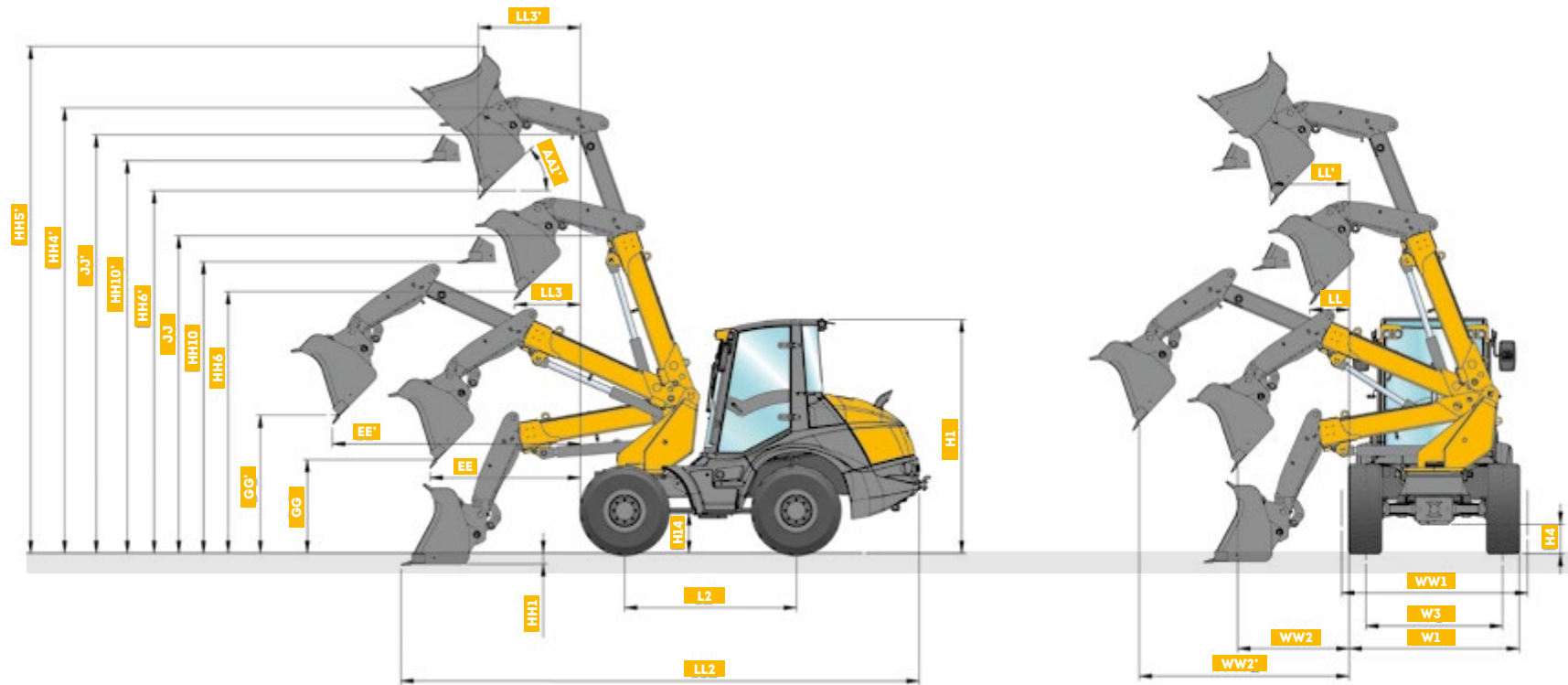

MACHINE DIMENSIONS	
BUCKET	STD. 0.90 m ³ (1.2 yd ³)
AA1'	45°
EE	1850 mm (6')
EE'	2850 mm (9'4")
GG	1140 mm (3'8")
GG'	1220 mm (4')
H1	2910 mm (9'6")
H4	390 mm (1'3")
H14	440 mm (1'4")
HH1	180 mm (0'6")
HH10	3500 mm (11'5")

MACHINE DIMENSIONS	
BUCKET	STD. 0.90 m ³ (1.2 yd ³)
HH10'	4490 mm (14'7")
HH4'	5120 mm (16'8")
HHS'	6250 mm (20'5")
HH6	3100 mm (10'2")
HH6'	4100 mm (13'5")
JJ	3950 mm (12'9")
JJ'	4900 mm (16')
L2	2085 mm (6'8")
LL	460 mm (1'5")
LL'	850 mm (2'8")

MACHINE DIMENSIONS	
BUCKET	STD. 0.90 m ³ (1.2 yd ³)
LL2	6270 mm (20'6")
LL3	840 mm (2'7")
LL3'	1230 mm (4')
W1	2060 mm (6'7")
W3	1660 mm (5'5")
WW1	2100 mm (6'9")
WW2	1470 mm (4'8")
WW2'	2470 mm (8'10")

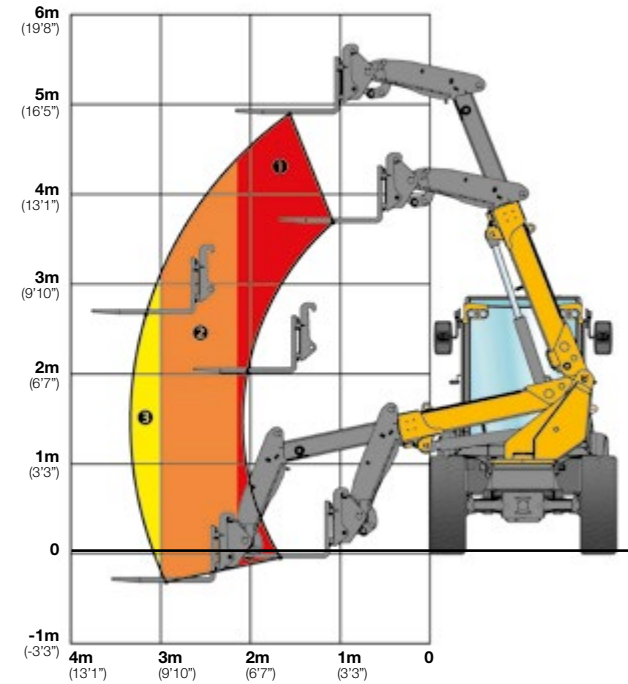
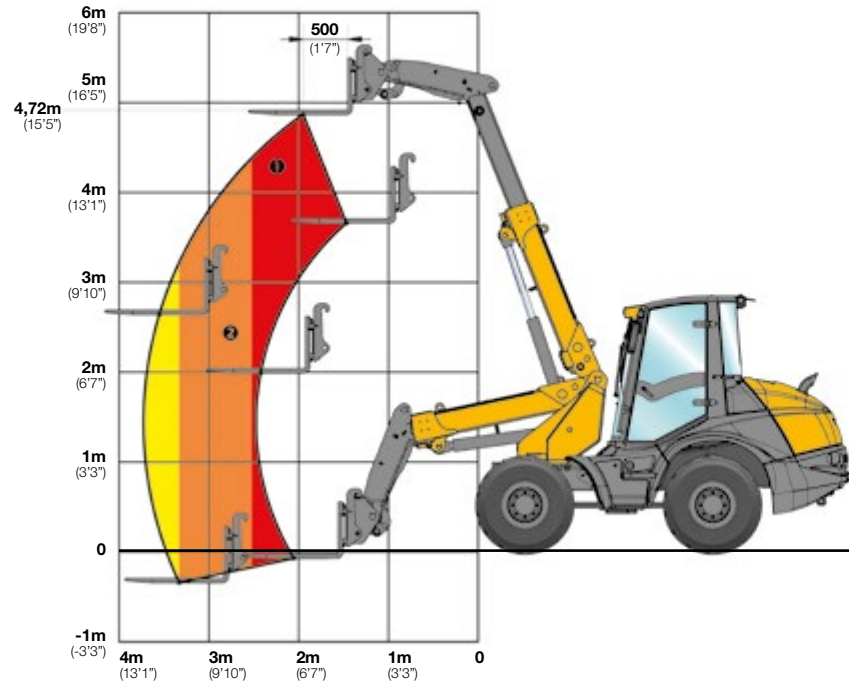

PAYLOAD (% tipping-load)	FRONTAL	90° SWIVELLED
even ground		
80%		
1	2135 kg (4,707 lb)	1600 kg (3,527 lb)
2	1550 kg (3,417 lb)	1015 kg (2,238 lb)
3	1410 kg (3,109 lb)	900 kg (1,984 lb)

All data based on standard tires.

All data are non-binding.

Changes are reserved without notice.

The order confirmation is exclusively decisive.

MECALAC FRANCE S.A.S.
2, avenue du Pré de Challes
Parc des Glaisins – CS 40230
Annecy-le-Vieux
FR - 74942 Annecy Cedex
Tel. +33 (0)4 50 64 01 63

**MECALAC BAUMASCHINEN
GMBH**
Am Friedrichsbrunnen
D-24782 Búdelsdorf
Tel. +49 (0)43 31/3 51-319

**MECALAC CONSTRUCTION
EQUIPMENT UK LTD**
Central Boulevard,
ProLogis Park
Coventry, CV6 4BX, UK
Tél. +44 (0)24 7633 9539

**MECALAC İŞ MAKİNELERİ
SAN VE TIC. LTD. ŞTİ.**
Ege Serbest Bölgesi Nilüfer 1 Sok. No: 34
35410, Gaziemir
İzmir - Türkiye
Tel. +90 232 220 11 15



WWW.MECALAC.COM